

# Montana Cross Country “T” Association – Rules

(Motioned and Passed October 16, 2022).

## **1. Rules for all Participating Cars, Drivers, and Owners.**

- 1.1. These Rules dated 10-16-2022 supersede all others. These Rules are intended to outline current acceptable practices. Deviation beyond these practices may result in disqualification or time penalty. See Rules for Timing. Directors are responsible for interpretation of all Rules pertaining to the Association and the assessment of time penalties. Decision of the Directors is final.
  - 1.1.1. Assure that your car complies with Montana Licensing and Insurance Regulations.
  - 1.1.2. No alcoholic beverages allowed in participating cars. Substantiated violation is cause for disqualification.
  - 1.1.3. Drivers exhibiting un-sportsman-like behavior or demeanor will receive one warning. Second infraction may result in disqualification upon review and affirmation of 2/3 of the remaining drivers.
  - 1.1.4. No more than two people allowed in an Endurance Car while under time.
  - 1.1.5. All drivers and relief drivers must be paid up members of the MCCTA.
  - 1.1.6. All drivers and relief drivers must sign and submit an Endurance Run Waiver and Inspection Form to the Treasurer.
  - 1.1.7. Do not tailgate or draft any vehicle. All drivers must maintain a safe following distance, but no closer than the ratio of 10 feet per 10 MPH, i.e., 50 feet at 50 MPH and so on. Report any infraction to the President. One infraction incurs one warning, a second infraction incurs disqualification.
  - 1.1.8. Place the name of sponsor or owner and hometown on both sides of all participating cars. Three (3) inch tall letters are preferred.
  - 1.1.9. All T's will be available for subsequent inspections at any time. Any member may initiate an inspection at any time, subject to approval by a majority vote of the Directors present.
- 1.2. All (Endurance Run) T's must be assembled from stock parts and/or reproduction parts equal to stock specifications, with the following exceptions allowed in Section 2 below.

## **2. Rules and Guidelines for Preparing an Endurance Run car.**

### **2.1. Body System.**

- 2.1.1. Use *an original style Model T body for year of car.* (10-16-2022.)
  - 2.1.1.1. All replacement body parts must be equal to stock specifications, made of metal, with a complete set of floorboards. Cars must have four fenders, splash aprons, running-boards, and if so equipped: front splash apron, dash, and radiator shell.
  - 2.1.1.2. Body and fenders must be painted.
  - 2.1.1.3. Use of hood optional.
- 2.1.2. **Turtle deck** may be replaced by a pickup box, or a substantially built box or turtle deck. Minimal length and width equal to size for stock turtle deck for the body, with floor, sideboards, and end-gate. Sides and ends to be no less than 6-inches high from the floor and made of no smaller than  $\frac{3}{4}$  wood.

**2.1.3. Sawed-off touring cars** allowed with a turtle deck, pickup bed, or substantially built box with sides and ends to be no less than 6-inches high from the floor and made of no smaller than  $\frac{3}{4}$  wood.

**2.1.4. Ignition Switch.** Equip body with a functional original type ignition switch.

**2.1.5. Lights.** Equip all cars with two headlights, one or more brake and tail lights. Brake and tail lights do not have to be a single unit. *All lighting must be functional.* (10-16-2022.)

**2.1.6. Turn Signals.** Allowed.

**2.1.7. Horn** of any type in working order required.

**2.1.8. Using stock** Engine splash pans *are optional.* (10-16-2022).

**2.1.9. Tops.** Non-Model T style and size tops not allowed. *Model T tops used on Touring and Roadster cars are optional, but if used, they must be foldable.* (10-16-2022). These stock type tops must meet the style, shape, dimensions, with *supporting wood and iron bows* (10-16-2022.) for the Ford body. *Fabric material optional. Side curtains optional.* (10-16-2022).

**2.1.10. Rearview mirror** required. *Additional side mirrors recommended.* (10-16-2022.)

**2.1.11. Windshield** must be stock for year of body. Do not alter. Use safety sheet or safety plate glass. Assure that the windshield completely closes for inspection sealing.

**2.1.12. Windshield Wiper.**

**2.1.12.1.** Windshield wiper of any type allowed.

**2.1.13. Seat and backrest** required. *Both* must be padded.

**2.1.14. Gauges.**

**2.1.14.1.** Gauges of any type allowed, as long as they do not affect the ignition system.

## **2.2. Chassis System.**

**2.2.1. Brakes.**

**2.2.1.1. Emergency Brakes.** Use stock type emergency brakes in good working order.

**2.2.1.1.1.** External auxiliary accessory brakes not allowed.

**2.2.2. Chassis Assembly.** The chassis-frame assembly (front axles, rear ends,) may be equipped with any year of stock T parts.

**2.2.3. Front Axle.**

**2.2.3.1.** Do not use Steering dampeners.

**2.2.3.2.** Use standard wishbone sizes.

**2.2.3.3.** Front wishbone accessory braces may be used on pre-1920 front axles.

**2.2.3.4.** Assure that all bushings, ball joints, shackle bolts, etc., are in good working order and all cotter keys are in place.

**2.2.3.5.** Wire wishbone studs together to prevent the studs un-screwing.

**2.2.4. Motor Mounts.**

**2.2.4.1.** **Belly bands** are allowed, but if the motor mount breaks, the car takes the standard penalty *of 1-hour.*

- 2.2.4.2. Belly bands cannot be used for support at any time.
- 2.2.4.3. Assessor pan arms are not allowed except for emergency repair while under time.

### **2.2.5. Rear Ends.**

- 2.2.5.1. Use stock Model T or Ruckstell rear ends locked in high.
- 2.2.5.2. Use a 40-tooth ring gear and an 11-tooth pinion. (3.64:1 ratio.)
- 2.2.5.3. Use stock roller bearings on the axles.
- 2.2.5.4. Use stock or modern drive shaft pinion bearings in the driveshaft pinion spool.
- 2.2.5.5. Use babbitt, bronze, roller, thrust washers, with steel thrust plates.
- 2.2.5.6. Neoprene seals allowed.
- 2.2.5.7. Use stock configuration spring sets. 7 leaves per spring set minimum.
- 2.2.5.8. Use stock Universal Joints as is or equipped with needle bearings and caps.
- 2.2.5.9. Cotter key or safety wire all bolt heads, studs, clevis pins, and nuts.

**2.2.6.Shock Absorbers.** Use and type of shock absorbers is optional.

**2.2.7.Spare Tire Carrier.** Spare tire and type of carrier are optional. (10-16-2022.)

**2.2.8.Tires.** Use stock type passenger tires consisting of 30x3, 30x3 1/2, 4.40 4.50 x 21, or 4.50x21. (~~Proposed 10-16-2022. Tabled 10-16-2022.~~)

2.2.8.1. **Radial tires** not allowed (2019).

**2.2.9.Wheels.** Use Model T type wheels, consisting of:

- 2.2.9.1. 21-inch Model T wire or wood spoke (10-16-2022) wheels
- 2.2.9.2. 21-inch Model A wire wheels
- 2.2.9.3. 30x3.5 wheels with wood spokes, aluminum spokes, aftermarket wire spoke type, or disk wheels.

2.2.9.4. **Wheel and tire assemblies.** *Balancing of wheel and tire assemblies is allowed.* (10-16-2022).

### **2.3. Cooling System.**

#### **2.3.1. Radiator.**

2.3.1.1. Use a new, or original, or rebuilt radiator made to stock dimensions including tanks and side brackets.

2.3.2. **Auxiliary Cooling.** *Do not use aftermarket spray bars to cool the radiator or engine.* (10-16-22). *See exception 2.3.5.1.*

**2.3.3. Fans.** Use of any Model T stock type fan and belt optional.

2.3.3.1. Use of v-type fan belt and pulleys allowed.

2.3.3.2. *Electric fans not allowed.* (10-16-2022).

2.3.4. *Do not use auxiliary coolant recovery tank. (6-2004).* (10-16-2022.)

#### **2.3.5. Water Pump.**

2.3.5.1. Use of *era type* water pump allowed. (10-16-2022.)

### **2.4. Electrical System.**

#### **2.4.1.Charging System.**

- 2.4.1.1. Battery.** Use one 6-volt type battery (6.9– volt maximum) or the engine’s unaltered magneto system to power the ignition coils. (10-16-2022.)
- 2.4.1.2. Accessory battery charging devices** must be disconnected. *This includes but is not limited to a magneto driven battery charger.* (10-16-2022.) Battery disconnect switches and fuses are allowed in the primary circuit, excluding the ignition system.
- 2.4.2. Ignition System.**
- 2.4.2.1. Timers.** Only stock Ford roller type, NewDay, Anderson Flapper type, Crystal, or TW timers allowed.
- 2.4.2.1.1. Brush Holders.** *Any non–electronic type of brush holder allowed.* Rush rollers allowed. Rollers may be of ball or needle bearing type.
- 2.4.2.1.2. Brush or Roller Material** used inside the above timers or brush holders is optional.
- 2.4.2.2. Quick couplers** not allowed.
- 2.4.3. Electronic Devices.** *Do not use electronic or converter devices to alter voltage, amperage, resistance or otherwise altering the ignition system.* (10-16-2022.)
- 2.4.3.1. Electronic Timers not allowed.** I.e., *I–timer, E-timer, Tru– Fire systems, etc.,* (10-16-2022.)
- 2.4.4. Coils.** *Use Ford or KW original or reproduction stock type coil units.* (10-16-2022.)
- 2.4.4.1. Ignition Coils** must ‘buzz’ while turning the engine over slowly with ignition switch on BAT. *Vibrator spring must pulsate while running the engine on BAT or MAG.* (10-16-2022.)
- 2.4.4.2. Master Vibrator devices** not allowed. (10-16-2022.)
- 2.5. Engine System.**
- 2.5.1. Reference Resource for Engine Specifications.** From the book, “Model T Ford, The Car That Changed The World”, 1994 by Bruce McCalley.

Model T engines are 22.50 horse power

Spark plug firing order: 1-2-4-3, number one starts at the front of the engine, (nearest radiator).

Note: These dimensions are from the Ford Service Course, and relate to new engines built after 1913. There may be variations over the years. Some dimensions will not apply to modern replacement parts (pistons, valves, etc.).

Crankshaft dimensions		
Length of bearings	Front	2"
	Center	2-3/16"
	Rear	3-1/8"
	Rods	1.505"
Bearing diameter (all)		1.248"
Overall length		25-5/32"
Camshaft dimensions		
Length		22-23/32"
Bearing diameters (all)		.748"
Bearing lengths	Front	1.967"
	Center	2-7/16"
	Rear	1.750"
Width of cams		7/8"
Diameter of heel of cam		13/16"
Greatest diameter of cam		1-1/16"
Flange diameter		1-3/4"
Flange width		1/4"
Dowel holes		.3120-.3125"
Thread	Large	13/16 x 16 USF
	Small	9/16 x 18 SAE
Cylinder bores		3.750" dia. 6.752" long
Cylinder head bolt holes		7/16 x 14
Camshaft bearing holes	Front	1.374-1.375"
	Center	1.372-1.373"
	Rear	.9985-1.000"
Main bearings		1.248-1.249"
Manifold ports		1-1/8"
		(With 1-1/4" countersink, 1/8" deep)

Pistons		
Diameter	Skirt	3.748-3.749"
	2nd ring	3.743-3.745"
	Top	3.738-3.740"
Ring grooves		1/4 x 13/64 deep
Pin bushing diameter		.740-.741"
Wrist pin diameter		.740-.741"
Wrist pin length		3-1/2"
Ring gaps (original rings)		
	Top	.003"
	Center	.005"
	Bottom	.008"
Push rods	Length	2-11/32"
	Diam.	.4355-.4365"
	Head dia.	1"
Push rod guide holes		.437"
Valves		
Diameter of head & upper edge of seat		1-15/32"
Diameter of lower edge		1-17/64--1-9/32"
Width of valve seat		3/32"
Angle of valve seat		45 degrees
Thickness of head		3/16"
Stem diameter		.3105-.312"
Overall length		4.974" +
Retainer pin hole		.110-.113"
		4-19/32" from valve seat line
Valve lift		7/32"
Valve tappet to stem clearance		.022-.032"
Valve ports		1-5/16"
Valve stem guide holes		.3125"

## 2.5.2. Block.

2.5.2.1. **Balancing.** Balancing of rotating *and reciprocating* parts is allowed.

Please see 2.5.3.6 and 2.5.3.7. (10-16-2022.)

2.5.2.2. **Camshaft.** Any camshaft that does not require relieving the cam bearing bores may be used.

2.5.2.2.1. **Camshaft bearings.** Material optional, i.e., babbitt, cast iron, or bronze.

2.5.2.2.2. **Camshaft bearing bores** must be standard size. Do not relieve camshaft bearing bores.

2.5.2.2.3. **Camshaft Timing Gear.** Use stock type timing gears or reproduction gears made of aluminum, bronze, fiber, nylon, or steel.

2.5.2.2.3.1. Adjustable timing gears allowed. (Oct. 2018).

2.5.2.2.3.2. Z-shaped woodruff keys may be used at the small timing gear. (Oct 2002).

2.5.2.2.3.3. Drilling offset timing holes into a T-type camshaft timing gear allowed. (Oct 2002).

2.5.2.2.4. **Coil Box.** Material type optional. (<1988).

2.5.2.2.4.1. Panel materials are optional, i.e., wood, plywood, plastic, plexiglass, etc.

2.5.2.2.5. **Connecting Rods.** Use of Model T Ford script rods *and/or*

*Snyder's New Babbitted Rods T-3026* allowed. (10-16-2022.)

2.5.2.2.5.1. Use connecting rods with the center-to-center of rod journal bore to wrist pin bore of 7.000". 7.030" c-t-c is the maximum length allowed.

- 2.5.2.2.6. Stock type rod bolts and nuts optional. Alternative connecting rod bolts with nut choice optional.
- 2.5.2.2.7. Rod cap dippers allowed and rod cap may be drilled for dipper oiling.
- 2.5.2.2.8. Grooving connecting rod babbitt for oiling allowed.
- 2.5.2.3. **Rod-Piston-Cap Assembly.** There must be one unmodified piston, rod and cap assembly in the engine. The other three (3) assemblies can be balanced to this one.
  - 2.5.2.3.1. **Exception.** *If using a set or partial set of Snyder's T-3026 New Babbitted Rods, one rod must be unmodified and the other three rod-piston-cap assemblies can be balanced to it. (10-16-2022.)*
  - 2.5.2.3.2. **Exception-LA.** *If using a Snyder's T-3026 New Babbitted Rod or set, with any Ford Script rod or set, one rod must be unmodified. (10-16-2022.)*
- 2.5.2.4. **Protrusion.** Do not allow any piston to protrude above the head gasket by more than 0.400-inches.
- 2.5.3. **Crankshaft.** Use a Ford script Model T crankshaft.
  - 2.5.3.1. Use a stock stroke of four-inches. +/- 0.030-inches allowed.
  - 2.5.3.2. Chroming, hardening, or grinding of crankshaft journals allowed.
  - 2.5.3.3. Maximum crankshaft journal diameter is 1.250-inches.
  - 2.5.3.4. Minimum crankshaft journal diameter is 1.208-inches.
  - 2.5.3.5. An offset Z-Key may be used on the crankshaft and small timing gear.
  - 2.5.3.6. Do not use counter-balancing devices with the crankshaft.
  - 2.5.3.7. Do not use a counter-balanced crankshaft.
- 2.5.4. **Cylinder Bores.** Do not use cylinder bores that are smaller than (standard) 3.750-inches or larger than 3.825-inches.
- 2.5.5. **Cylinder Head.** Any cast iron original Ford script flat head (low or high) can be used.
  - 2.5.5.1. The head can be milled, but the combustion chambers are limited to 270 cubic centimeters minimum each.
    - 2.5.5.1.1. Measure the combustion chamber volumes without head gasket or spark plug. Fill the spark plug hole flush with modeling clay.
    - 2.5.5.1.2. One combustion chamber cannot be modified.
  - 2.5.5.2. Do not add material to any combustion chamber.
- 2.5.6. **Decking the Block.** The block may be decked, but no portion of the pistons can protrude out of the deck more than 0.400-inch from the top surface of the head gasket in use.
- 2.5.7. **Lifters (Tappets).** Adjustable flat tappet lifters (push rods) of stock dimensions, stem oversize to 1/32" allowed. (1962).
- 2.5.8. **Main Bearings.** Grooving and drilling babbitted main bearings for oiling allowed.
- 2.5.9. **Pistons.** Use stock type cast iron or aluminum pistons conforming to the Association's drawing shown below.
  - 2.5.9.1. **Cast Iron Pistons.** Use a full set of 0.250-inch width rings on cast iron pistons.
  - 2.5.9.2. **Aluminum Pistons.** Use two 0.125-inch width compression rings and one 0.187- inch oil ring with aluminum pistons. Multi-piece piston rings allowed.

2.5.9.3. Snyder's Premium pistons T-3021 are allowed. (2017).

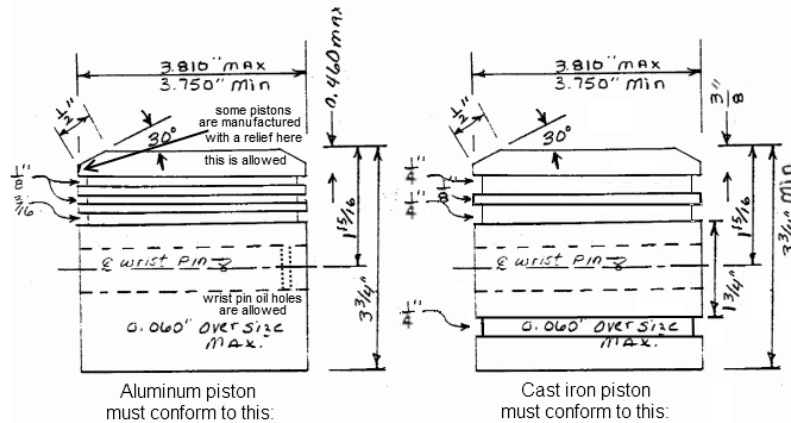

2.5.9.4. Drilling oil holes into wrist pin boss allowed. See above drawing.

2.5.9.5. Knurling pistons allowed.

## 2.5.10. Rod-Cap-Piston-Assembly See 2.5.3.2.

2.5.10.1. Piston Protrusion. See 2.5.3.3.

2.5.11. Porting. Do not grind, enhance, or alter any intake or exhaust port of the block or of the manifolds.

2.5.11.1. *Deburring bore hole ends. Vacant.* (10-16-2022)

2.5.12. Valves. Use stock T valves, reproduction stock-type valves, stainless steel, and swirl polished valves meeting the following dimensions allowed. (2003)

2.5.12.1. Minimum valve stem diameter is 5/16-inch (0.3125-inch).

2.5.12.2. *Absolute maximum valve head diameter is 1.515–inches.* (10-16-2022)

2.5.13. Valve Seats. Hardened valve seats allowed.

2.5.13.1. Use a valve seating face of 45 degrees. Radiused, 45 degree, or three angle grinds allowed on the valve seat.

2.5.14. Valve Retainers. Use stock pin-type valve retainers or modern two-piece keepers with retainers.

2.5.15. Valve Springs. Use stock Model T or stock Model A Ford valve springs in the valve train.

## 2.6. Exhaust System.

2.6.1. Exhaust Manifold. Use stock cast iron or new manufactured cast iron exhaust manifolds with ports not to exceed 1-1/8" I.D.

2.6.2. Exhaust Ports. No grinding or performance enhancing alterations of the exhaust ports allowed.

2.6.3. Exhaust Pipe. Use at least 36 inches of 1-1/2" *outside diameter (nominal size)* (10-16-2022) exhaust pipe, securely attached to and extending from the exhaust manifold.

2.6.3.1. Vacant.

2.6.3.2. Do not use exhaust wrapping on the first 36 inches of the exhaust pipe or on the exhaust manifold. (October 11, 2015.)

2.6.4. Muffler. Using a muffler of any type is optional.

## 2.7. Fuel System.

### 2.7.1. Gas Tank.

2.7.1.1. Use a stock-type gas tank, stock to the body, and mounted in the stock position.

2.7.1.1.1. Exception: Gas tanks for 1925 and earlier bodies may be raised by 1-5/8".

2.7.2. Fuel. All cars must use straight automotive pump gasoline as fuel during the Endurance Run. (2004). No fuel additives allowed. See Section 3. Rules for Inspection of Endurance Cars, 3.1.

2.7.3. Fuel Lines. Do not use fuel lines that exceed 3/8" I.D.

2.7.4. Fuel Strainers. Allowed.

## 2.8. Intake System.

### 2.8.1. Carburetor.

2.8.1.1. Use NH or Ford F swayback carburetor.

2.8.1.2. Do not add any material to the interior of the carburetor.

2.8.1.3. The throat of the carburetor may be smoothed in certain areas as shown on the Association's gif drawing below as long as the Association's 0.713" gauge (actual spherical diameter is 0.7130" +/- 0.0003") does not pass through the venturi from either side.

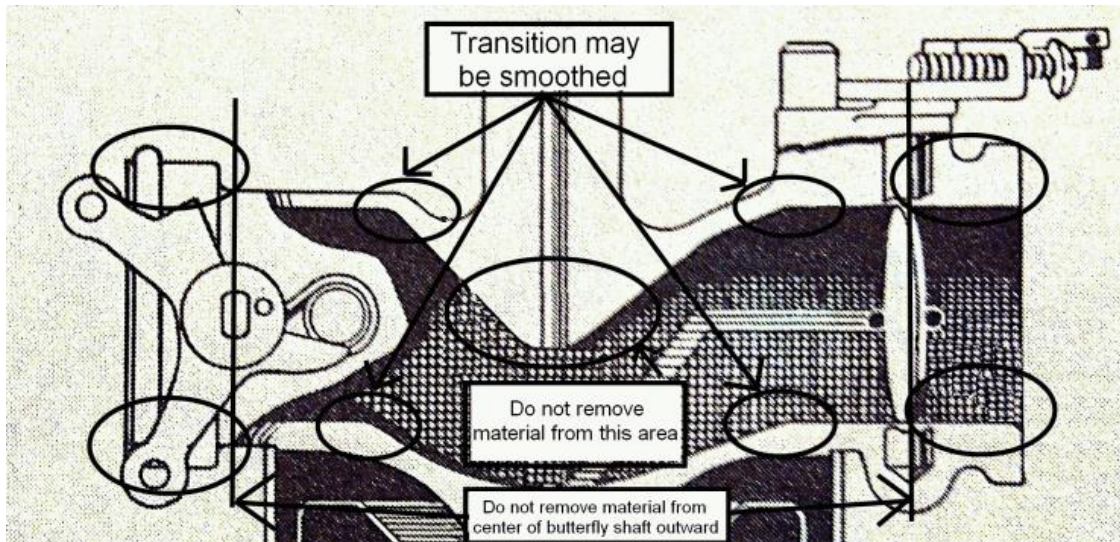



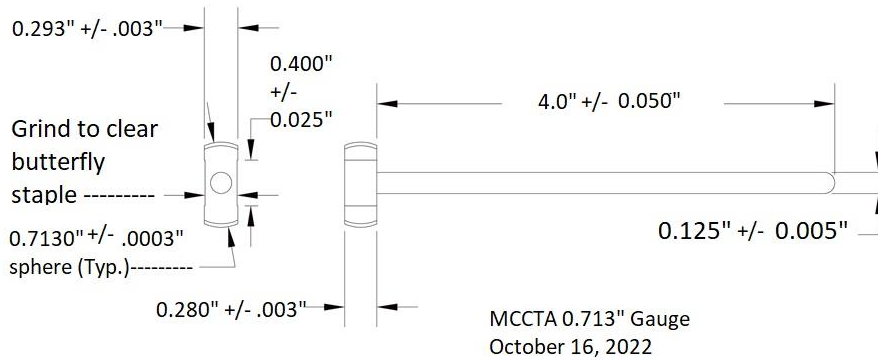

**2.8.1.3.1.** Also assure that the association's W-gauge does not engage the gauge handle when inserted through the choke throat, past the venturi, and into manifold side throat.

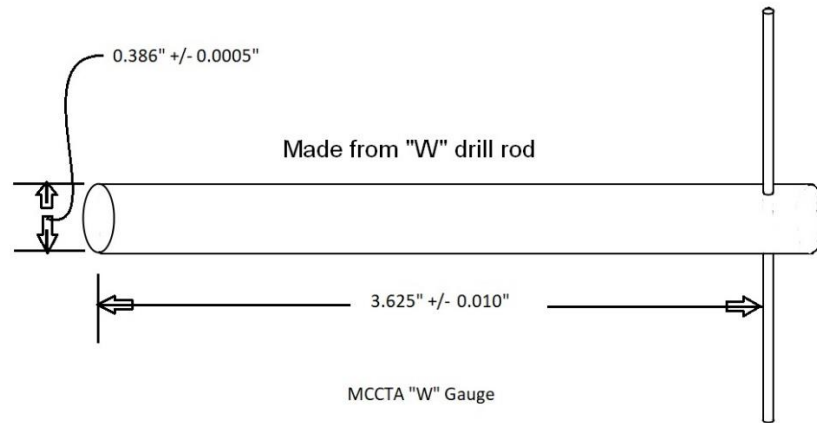

**2.8.1.3.1.1. Associations "W" Gauge.**

**2.8.1.4.** Carb must be complete with stock parts. Use stock choke shaft and butterfly, throttle shaft and butterfly, spray needle, float, and jets.

**2.8.1.4.1.** Choke and throttle shafts must pass a visual inspection for stock uniform shaft dimensions with no obvious modifications. Butterflies must be original size.

**2.8.1.4.2.** Use a stock spray needle with diameter of 0.125" +/- 0.015".

**2.8.1.4.3.** Assure that the association's 0.713" (actual diameter is 0.7130" +/- 0.0003") gauge does not go through the swayback venturi opening from the choke or throttle openings.

**2.8.2. Intake Manifold.** Only stock cast iron, stock aluminum, or new manufactured aluminum intake manifolds with ports not to exceed 1-1/8" I.D. allowed. Chaffin's aluminum manifolds are allowed if the gland ring has an 1-1/8" or less gland ring in place.

**2.8.2.1. Intake Manifold Ports.** No grinding or performance enhancing alterations of the intake manifold ports allowed.

**2.8.3. Hot Air Stove.** Using an original type hot air stove is allowed.

**2.9. Neoprene Seals.** Use of neoprene seals is optional.

**2.10. Oiling System.**

**2.10.1.** Modifications to the **inside oiling system** not allowed.

**2.10.2.** One **outside oil line** running from the hogshead, mag post plug, or band door cover to the front of the engine pan allowed.

**2.10.2.1.** *Maximum nominal inside or outside diameter of outside oil line is 0.5–inch.* (10-16-2022.).

**2.10.3. Zerks.** Grease zerks used in place of oil and grease cups allowed.

**2.11. Transmission System.**

**2.11.1. Balancing** rotating transmission parts allowed.

**2.11.2. Bands.** Assure all bands are in good working order.

**2.11.3. Band material** optional, i.e., kevlar, cotton, bonded, wood, etc.

**2.11.4. Triple gear** stock-type z-bronze bushings may be replaced with needle bearings.

**2.11.5. Triple gear** flywheel pins may be replaced with the hardened type. (10-21).

**2.11.6. Fourth main bearing,** use babbitted or modern roller bearing type. (>1986).

**2.11.7. Oil Screen** maybe use below the transmission door cover.

**2.11.8. Steel or reproduction iron transmission drums** (10-16-2022) can be used in place of the cast iron Ford script drums.

**2.11.9. Clutch Disks.** Use Ford original, Watts, or Turbo 400 clutch disks.

### **3. Rules for Inspection of Endurance Cars.**

**3.1. Fuel in tank before Inspection.** Use straight automotive pump gas as fuel during the Endurance Run time, starting with inspection and continuing until the end of the Endurance Run. (B1). *Assure there is no more than 5 gallons of fuel in the Endurance Car's gas tank. Use only straight pump gas from that point forward. Do not add fuel from auxiliary gas containers at any time. Exception: Taking verified straight pump fuel from a container on a trouble truck after the car runs out is allowed. (10-16-2022.)*

**3.2. All ignition timers** will be internally inspected during the inspection procedure by a designated inspector. The driver will remove the timer from the front plate to allow a visual inspection of the timer. If the timer in use is of the correct type, the inspector will coat #1 timer wire connections with designated inspection paint. Paint will be applied to the end of the 10-32 threads on #1 ignition wire at the coil box and on #1 wire terminal at the timer.

**3.2.1. The driver is responsible** for periodically inspecting all seals and ensuring that they are intact during the Endurance Run. If a seal or seal wire is found to be broken or suspect the driver will immediately inform all directors present for further review and resolution. Replacing the inspected timer is allowed (either under time or not under time). When timer is replaced under time the driver must immediately inform an official at the first opportunity after the timed leg. Before replacing timer while not under time the driver must inform an inspector before breaking the seals and removing the timer and seals. After installation of a replacement timer an official will install new seals. (10-16-2022.)

3.2.2. (Additional paint seal, see 3.7 below.)

**3.3. New stainless-steel wires and lead seals** will be placed on each Endurance Car by the inspection committee during inspection each year. (October 10, 2021) Drivers are required to remove and properly discard existing seals and seal wire from the head bolts, carburetor bolts, rod door bolts, and windshield sticks before inspection begins. (10-2020).

**3.4. Drill through the following bolts** for accepting seal wire. Paint these drilled bolts a contrasting color.

**3.4.1.** Two head bolts, next to each other.

3.4.2. Two rod door bolt heads, across from each other.

3.4.3. Two carb to intake manifold bolts, through the threaded portion, and below the nut.

3.5. Provide room for seal wire to assure the windshield cannot be opened. (10-16-2022.)

3.6. Seal Guns. Two seal gun button (stamp) heads will be drawn from the supply at the beginning of the inspection and used in the seal guns for that year. The seal gun and buttons will remain in position of the President for the remainder of the Endurance Run. (10-16-2022.)

3.7. Paint Clamp Bars on Intake Manifold Bosses. Inspector's will place the same paint used on the timer (3.2 above.) on to the interface of the Manifold clamp bars and the intake manifold boss. If this paint seal becomes disturbed, notify the directors asap. Cars with disturbed paint may be disqualified or receive a 15-minute time penalty, depending on the director's decision. (10-16-2022)

#### 4. Rules for Timing Endurance Cars and Penalties.

4.1. Drivers are responsible for following the prescribed route. Failure to travel the entire prescribed route will result in an assessment of slow time for that leg plus a penalty of 15 minutes. Flaggers or signs may be posted as deemed necessary or advisable.

4.2. Routes should be planned to avoid running through stoplights under time.

4.3. Each car will come to a complete stop before starting at the Timer's direction.

4.4. Timing will begin as designated for each car whether or not the car is on the starting line. Starting times can be adjusted at the Timer's discretion. If the Timers recognize a beneficial savings in time, a lagging car may be sent out ahead of its designated time. Usually this will be discussed with the Directors ahead of time. Time will start for this car when it leaves the starting line.

4.5. Removal of cylinder head or rod door pan at stop (not under time) or on tour day, if tour day occurs during the endurance run, will impose a time penalty of 1-hour. Report this infraction to the directors immediately. Removal of head or pan while under time imposes no penalty. Removal of head or rod door pan must be reported to the directors at the first opportunity for replacement of seal.

4.6. Changing the carburetor and or intake manifold (10-16-2022) imposes a time penalty of 15 minutes *for each occurrence*. Report the infraction to a director immediately. Replacement carburetor *and or intake manifold* (10-16-2022.) must meet the requirements stated in *the 2.8 Intake System Section*. (10-16-2022.)

- 4.7. **Trailered cars** will receive slow time for each leg when using a trouble trailer. Disabled cars will receive slow time for each leg not completed thereafter until their car resumes a subsequent leg again.
- 4.8. **Speed Limit Violation Penalties.** See Section 5.2.
- 4.9. **Replacement of complete engine** is cause for disqualification.
- 4.10. **Placement position** results for cars that do not complete the entire endurance run will be based and ranked on actual mileage completed.
- 4.11. **Homologated** (approved) cars will be placed higher in the finish order than non-homologated cars. (October 10, 2021.)

## 5. **Rules for Radaring Endurance Cars.**

- 5.1. **The President will pick one non-driver person to be in charge of the radar guns.** This person will select the locations for radaring and the other non-driver persons for running the radar guns. This person and helpers are on their honor to not discuss the radar location whereabouts with anyone else. (October 10, 2021.)
- 5.2. **Any driver exceeding the posted speed limit** by 6 MPH will incur a 6-minute time penalty. The 6-minute time penalty will be increased by 1-minute per each MPH over the 5-MPH allowance, i.e., 10 MPH over incurs a 10-minute time penalty. (October, 2020.)
  - 5.2.1. **Challenge Exception.** Electronic device challenging the Radar Gun Reports: If you have evidence from within the posted speed limit zone from an electronic device that clearly indicates your vehicle, the speed limit sign, and your vehicular speed, you may use it to challenge the Radar Report. Show your evidence to the Directors and they will decide to impose the Radar Report penalty or not. (October, 2020.)

## 6. **Rules for Tearing down Endurance Cars.**

- 6.1. **All Directors and Drivers** are expected to attend the teardown.
- 6.2. **After the last flag,** the top 6 position cars will immediately head to the teardown location *without pausing for repairs or adjustments.*
  - 6.2.1. *Do not work on your car from the last flag forward. 10–16–2022).*
- 6.3. **The Car in First-Position** will be torn down immediately following the last flag by a panel of five inspectors.
  - 6.3.1.1. The driver in the top position at teardown cannot be an inspector, but the next five placed drivers are expected to be inspectors for teardown.
- 6.4. **The Teardown Manual** is a supplement to printed Rules. If there is a conflict between the teardown manual and the printed rules, then the printed Rules will take precedence.
- 6.5. **Inspector Duties.** If any inspector does not want to fulfill the teardown duty, then the next placed finishing car driver can fill the vacant inspector void, and so on.
  - 6.5.1. **The teardown inspectors** will elect a leader who will use the Teardown Manual to guide the procedure, step-by-step, *and record the findings for all drivers to see.*

- 6.5.2. Inspectors are to use and follow the procedures, line-by-line, in order of presentation found in the Association's Teardown Manual.
- 6.5.3. The five teardown inspectors will bring all issues (10-16-2022.) to the vote of the Directors.
- 6.5.4. Broken Seals. Inspectors finding broken seals or seal wires will inform the Directors immediately and wait for ruling. (10-16-2022).
- 6.6. Director Duties. Directors will discuss and vote to accept or reject items of question brought to them by the inspectors.
- 6.6.1. *The Directors may vote to put the concern to a vote of the drivers. (10-16-2022).*
- 6.6.1.1. If a director is also the driver of the car in question, that Director cannot vote on concerns with their car.
- 6.7. Driver Duties. All drivers should be on hand to witness and vote on items or concerns when directed to.
- 6.7.1. All drivers will be allowed to view the teardown from a respectable distance.
- 6.7.2. Any driver has the right to consult with an inspector on any issues concerning the cars.
- 6.8. Disruptive people will leave the area. (October 10, 2021).
- 6.9. Association's Gauges. *The Association's gauges shall meet the drawing specifications listed in the rules. (10-16-2022).*
- 6.9.1. "713-gauge" testing procedure. (10-16-2022).
- 6.9.1.1. *Identify the following:*
- 6.9.1.1.1. *The "713 test gauge" spherical measurement is 0.7130" +/− 0.0003"*
- 6.9.1.1.2. *A "713 check gauge" having a spherical measurement of 0.7130" +/− 0.0003" is only used if the "713 test gauge" passes (through the venturi).*
- 6.9.1.1.3. *A "714 special gauge" having a spherical measurement of 0.7140" +/− 0.0003" is only used if the "713 check gauge" passes (through the venturi.)*
- 6.9.1.2. *Remove the spray needle from the carburetor.*
- 6.9.1.3. Step 1: *The driver will select one inspector to use both gauges ("713 test gauge" & "713 check gauge") and test the carburetor. After the selected inspector has finished the select inspection, then the remaining 4 inspectors will also perform this test.*

- 6.9.1.4. Step 2:** *Identify the gauge to use and confirm (with measurement by a micrometer) that it meets the drawing specification of 0.713–inch diameter. If the gauge does not meet the specification, then set it aside and select another gauge, meeting specifications.*
- 6.9.1.5. Step 3:** *Following the above instructions, gently insert the gauge into the carburetor throat and test if it goes beyond the venturi.*
- 6.9.1.5.1.** *If the gauge stops with gentle pressure from either ends of the carburetor, then the venturi being tested passes the 713–test. Continue with the 6.10.2 W–GAUGE TEST PROCEDURE (below).*
- 6.9.1.5.2.** *If the gauge goes through the venturi without an interference fit, stop Step 3 and continue to step 4.*
- 6.9.1.6. Step 4:** *In this case the Association’s check gauge will be used. The check gauge is also a 713 gauge that meets the specified drawing but is only used when Step 3 gauge test result was a fail. If the check test gauge ‘sticks’ or does not go pass then the venturi shall be deemed ok. As a courtesy, let the driver know that this carburetor is very close to a potential failure. If the check gauge passes then continue to step 5.*
- 6.9.1.7. Step 5:** *Using the 714 special gauge, again test the carburetor.*
- 6.9.1.7.1.** *If the gauge passes beyond the venture (again NOT USING PRESSURE) then the carburetor has failed and will be disqualified.*
- 6.9.1.7.2.** *If the 714 gauge does not go through the venturi, then car will be assigned a 15–minute time penalty.*
- 6.9.2. W–GAUGE TEST PROCEDURE (10–16–2022).**
- 6.9.2.1. Step 1:** *Identify the W–gauge to be used, confirm that it meets the Association’s W–Gauge drawing, if not discard and use another gauge that meets the Association’s W–Gauge drawing.*

6.9.2.2. Step 2. Gently insert the W-gauge from the choke side of the carburetor.

6.9.2.2.1. If the gauge stops without engaging the handle under light pressure, then the Carburetor meets the W-gauge specification.

6.9.2.2.2. If the gauge slides into the venturi up to the handle stop then the test is a FAIL.

6.9.2.2.2.1. Failed W-gauge test will result in disqualification.

6.10. **Disqualification.** If the first-position car is disqualified, the next place lower will be inspected, and so on, until a car has been found qualified. See 4.11 Homologated cars.

6.11. **Members will be given 20 minutes** to view and check any part removed from the car and those parts remaining with the car.

6.12. **The teardown committee** will assist in assembling the car(s) if the owner(s) agrees. (10-16-2022.)